

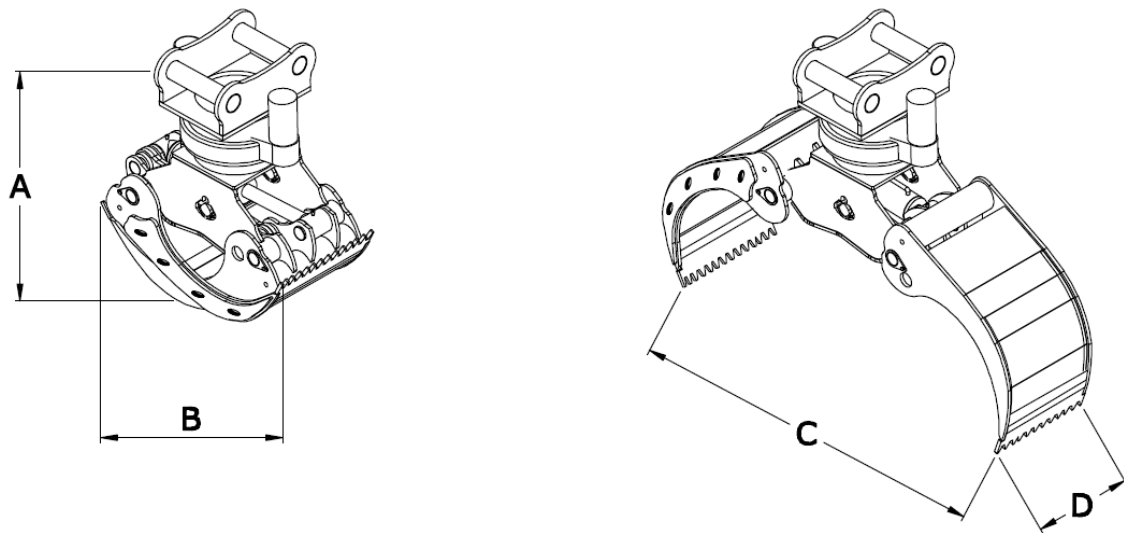

TIMBER GRAPPLE/ CNC TG 3T
HOLZGREIFER/CNC TG 3T



MODEL MODELL	Weight Gewicht Kg	Capacity Kapazität Ton/Tonne	Working Pressure Arbeitsdruck Max. Bar	A	B	C	D
MHT2	600	3	220	1150	1050	1750	500

Technical Data /Technische Daten

Capacity /Kapazität	3 Tons/Tonnes
Gross Weight /Bruttogewicht	600 Kg
Working Principle /Arbeitsprinzip	Hydraulic/Hydraulisch
Working Pressure /Arbeitsdruck	220 Bar
Grip Pressure /Griffdruck	130 Bar
Rotator / Rotator	Double/Doppelt Hydro Motor - 360°
No. Theeth/Zinken	2
Wearing Plates/Verschleißplatten	Hardox 450